

**ROMANIA NETWORK**



**ACE-FORMA**

SC FORMA SA. 3 Calea Nationala Botosani 710001.Romania.

Contact:



ACE / Producator de echipamente originale isi rezerva dreptul de a modifica orice specificatii fara a anunta. Dimensiunea greutatea si capacitatea mentionata, ori sunt aproximative. Accesoriile prezentate nu fac parte din echipamentul standard.

[www.forma-romania.ro](http://www.forma-romania.ro)

**ACE-FORMA**

**MOTOSTIVUITOR**

Capacitate : 3 tone.  
Putere Motor : 49.5 CP.  
Robust și fiabil  
Motostivuitor.



Nothing beats an **ACE-FORMA**

**ACE-FORMA**

Macara hidraulic mobila



Camion cu Macara



Macarale turn - mobila



Buldoexcavator



Incarcare frontal



Macarale turn



Motostivuitor



Nothing beats an **ACE-FORMA**







## Date tehnice

Model			AF-30 D	
Capacitate de ridicare	kg		3000	
Centru de greutate al incarcarii	mm		500	
Actionare			Motor diesel	
Pneuri			Pneumatice	
Roti			2/2	
Inaltimea maxima de ridicare (standard)	mm		3000	
Marimea furci (L x l x H)	mm		1070 x 125 x 45	
Bascularea dispozitivului de ridicare	Grade		6° - 12°	
Lungime totala fara furca	mm		2680	
Latime totala	mm		1225	
Inaltimea totala cu ridicatorul in pozitie inferioara	mm		2070	
Inaltime totala cu ridicatorul in pozitie superioara	mm		3645	
Inaltimea de protectie	mm		2090	
Raza de rotire (exterioara)	mm		2400	
Latimea culoarului la o curba de 900 (adaugati lungimea de incarcare si jocul)	mm		2885	
Viteza (e)	Deplasare (inainte/inapoi)	Cu incarcatura	Km/h	18,50
		Fara incarcatura	Km/h	20
	Ridicare	Cu incarcatura	mm/s	470
		Without Load	mm/s	520
	Coborare	Cu incarcatura	mm/s	550
Fara incarcatura		mm/s	520	
Panta maxima admisa	Cu/fara incarcatura	%	18.5 / 19.5	
Greutate totala		Kg	4410	
Distribuirea greutatii	Cu incarcatura		Kg	6562
			Kg	890
	Fara incarcatura		Kg	1780
			Kg	2630
Dimensiunea pneurilor	Fata			28*9-15-12 PR
	Spate			6.50-10-10 PR
Distanta dintre osii		mm		1700
		mm		1000
Banda de rulare	Fata	mm		1000
	Spate	mm		970
Garda de sol	Cel mai scazut punct (catarg)	mm		110
	Cadru	mm		115
Frana(e)	Service			Hidraulica -pedala
	Parcare			Mecanica -maneta
Baterie	Tensiune/capacitate	V / AH		12 /100
Motor	Model			A 490
	Putere nominala	Bhp/r.p.m		49 CP la 2650 rot/min
	Cuplu nominal	N.m (Kg.m)/r.p.m		148 / 1800
	Numar de cilindri			4
	Cilindree	Ltrs		2.54
	Capacitatea rezervorului de motorina	Ltrs		60
Transmisia	Numar viteze inainte/inapoi	Inainte inapoi		1/1(automat) 2/2(comutare manuala)(optional)
Operating Pressure	Pentru ridicator	Kg/cm <sup>2</sup>		175

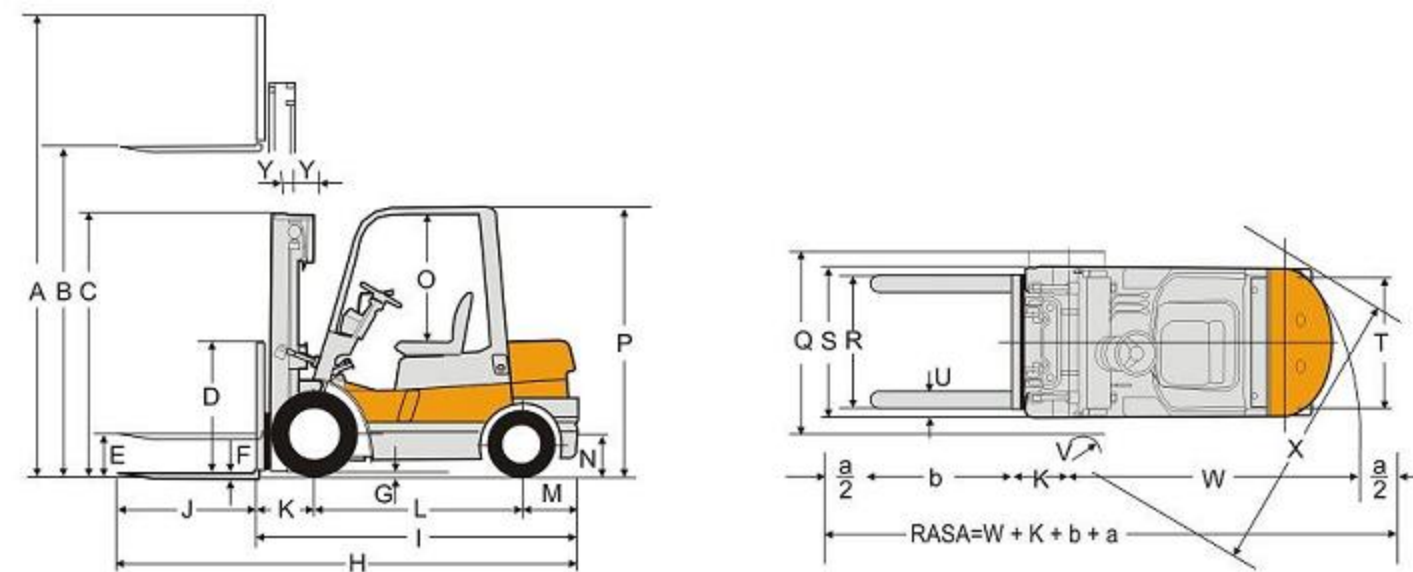

## DIMENSIUNI STANDARD

Model	AF 30D
	mm
A. Inaltimea totala cu furca ridicata	3645
B. Inaltimea max. a furcii	3000
C. Inaltimea ridicatoarei in pozitie inferioara	2070
D. Inaltimea de sprijin a furcii(de la suprafata furcii)	1230
E. Ridicare libera	180
F. Grosime furca	45
G. Inaltimea min.(la baza catargului)	110
H. Lungime totala(cu furci)	3750
I. Lungime totala(fara furci)	2680
J. Lungime furca	1070
K. Consola de furca	489
L. Distanta dintre osii	1700
M. Consola spate	491
N. Inaltimea de cuplare	308
O. Distanta de la scaun la plafonul cabinei	1040
P. Inaltime totala (inaltime vde protectie)	2090
Q. Latime totala	1225
R. Reglare laterala dintre furci	250-1090
S. Banda de rulare(fata)	1000
T. Banda de rulare(spate)	970
U. Latime furca	125
V. Raza interioara de rotatie	200
W. Raza exterioara de rotatie	2400
X. Intersectare minima a aleilor	2110
Y. Unghiuri de inclinare	6° - 12°

RASA = Right Angle Stacking Aisle, a = Clearance, b = Load Length

# MOTOSTIVUITOR

## ECHIPAMENT STANDARD

- Catarg cu vedere larga
- Contragreutate
- Furci standard
- Servodirectie
- Role de fixare
- Protectie superioara
- Scaun standard (reglabil)
- Bara pentru tractiune
- Filtru de aer
- Maneta pentru frana de mana
- Manete de comanda pentru ridicare si inclinare
- Supapa de comanda cu 3 cai
- Joja de ulei TC
- Filtru hidraulic de retur
- Filtru de ulei TC
- Ventil de inchidere al circuitului de ridicare
- Priza de aer superioara
- Rezervor pentru radiator
- Volan cu reglare a inclinarii
- Semnalizatoare de intoarcere
- Ceas
- Termometru pentru temperatura apei
- Indicator nivel pentru motorina
- Indicator de avertizare asupra presiunii uleiului din motor
- Indicator al incarcatorului electric
- Faruri halogene
- Lampi spate combinate
- Oglinzi retrovizoare
- Avertizor sonor pentru mers inapoi
- Claxon electric
- Comutator electric de siguranta(TC)
- Poada din material de cauciuc
- Trusa de scule

## ECHIPAMENTE OPTIONALE

- Roti frontale duble
- Pneuri masive
- Extinctor
- Cabina pretabila pentru orice tip de vreme
- Transmisie mecanica
- Parascantei
- Convertizor catalic
- Amortizor cu apa
- Sistem alimentare a motorului cu combustibil GPL

## ACCESORII OPTIONALE

- Catarg de tip diferit (vezi detalii ale catargului)
- Prelungiri furca
- Dispozitiv lateral
- Furci articulate cu cupa
- Gheara pentru balot sul de hartie
- Gheara pentru pachetebalot
- Furci rotative
- Manipulator butoaie
- Dispozitiv macara
- Berbec

## DIAGRAMA DE INCARCARE



## DETALII CATARG

Tip de catarg	Inaltimea de furca (mm)	Capacitate de ridicare (kg)		Inaltimea ridicatoarei (mm)		Ridicare libera (mm)	
		AF200	AF300	AF200	AF300	AF200	AF300
Catarg dublu 3m (Std.)	3000 mm	2000	3000	2000	2070	180	180
Catarg dublu 3m (Fullfree)	3000 mm	2000	3000	2000	2070	1500	1500
Catarg dublu 3.7 Mtrs.	3700 mm	2000	3000	2390	2400	180	180
Catarg triplo 4.5 Mtrs (Fullfree)	4500 mm	1700	2200 / 2700**	2000	2070	1500	1500
Catarg triplo 6 Mtrs. (Fullfree)	6000 mm	800	1050 / 1950**	2650	2800	1920	1920

\* Pretabil pentru patrundere in containere.  
\*\* Cu roti duble frontale.

